

## Quickie® Q700®-UP M

**Supplier:** This manual must be given to the user of this wheelchair.

**User:** Before using this wheelchair read this entire manual and save for future reference.

Owner's Manual

## Quickie® Q700®-UP M

**Distribuidor:** Este manual debe ser entregado el usuario de esta silla de ruedas.

**Usuario:** Antes de usar esta silla de ruedas, lea este manual en su totalidad y guárdelo para futura referencia.

Manual de Instrucciones

Cada una de las sillas se envía con un manual de instrucciones en inglés. El manual en español y francés está disponible en formato PDF en nuestra página en Internet: [www.SunriseMedical.com](http://www.SunriseMedical.com). Ingrese a la página del producto específico para descargar el manual, o comuníquese con el proveedor autorizado de Sunrise Medical.

## Quickie® Q700®-UP M

**Au Fournisseur:** Ce manuel doit être remis à l'utilisateur de ce fauteuil roulant.

**Utilisateur:** Avant d'utiliser ce fauteuil roulant, lisez l'intégralité de manuel et conserver pour référence future.

Chaque fauteuil est livré avec un manuel d'instructions en anglais. Les versions en espagnol et en français sont à votre disposition en format PDF sur le site : [www.SunriseMedical.com](http://www.SunriseMedical.com). Veuillez vous rendre à la page de votre produit pour télécharger le manuel dans la langue souhaitée, ou contactez un fournisseur agréé Sunrise Medical.

Manuel d'instructions

P/N 247556 Rev. B

Instructions for Use

# QUICKIE® Q700®-UP M Seating Manual

**SUNRISE MEDICAL LISTENS**

Thank you for choosing a Quickie® wheelchair. We want to hear your questions or comments about this manual, the safety and reliability of your chair, and the service you receive from your Sunrise dealer. Please feel free to write or call us at the address and telephone number below:

**SUNRISE MEDICAL (US) LLC**  
Customer Service Department  
2842 N. Business Park Avenue  
Fresno, CA 93727 USA  
(800) 333-4000



[www.SunriseMedical.com/register](http://www.SunriseMedical.com/register)

Please register your wheelchair, and let us know if you change your address. This will allow us to keep you up to date with information about safety, new products, and options to increase your use and enjoyment of the wheelchair.

You can also register your product at:  
[www.SunriseMedical.com/register](http://www.SunriseMedical.com/register)

**FOR ANSWERS TO YOUR QUESTIONS**

Your authorized dealer knows your wheelchair best, and can answer most of your questions about chair safety, use, and maintenance.

For future reference, please fill in the following:

Dealer: \_\_\_\_\_

Address: \_\_\_\_\_

Telephone: \_\_\_\_\_

Serial #: \_\_\_\_\_ Date/Purchased: \_\_\_\_\_

**ADDITIONAL INFORMATION YOU SHOULD KNOW**

No component of this chair was made with Natural Rubber Latex.



**DISPOSAL AND RECYCLING INFORMATION**

When this product reaches the end of its life, please take it to an approved collection or recycling point designated by your local or state government. This product is manufactured using a variety of materials.

Your product should not be disposed of as ordinary household waste. You should dispose of your product properly, according to local laws and regulations. Most materials that are used in the construction of this product are fully recyclable. The separate collection and recycling of your product at the time of disposal will help conserve natural resources and ensure that it is disposed in a manner that protects the environment.

Ensure you are the legal owner of the product prior to arranging for the product disposal in accordance with the above recommendations.

## II. TABLE OF CONTENTS

I.	INTRODUCTION.....	2	5.0	SETTING UP THE WHEELCHAIR.....	11
II.	TABLE OF CONTENTS.....	3	5.1	Seating system.....	11
1.0	USER INFORMATION.....	4	5.2	Seat height.....	11
1.1	This user manual.....	4	5.3	Set seat depth.....	11
1.2	For further information.....	4	5.4	Control system program.....	11
1.3	Symbols used in this manual.....	4	5.5	Set armrest width.....	12
2.0	SAFETY.....	5	5.6	Pre-set reclining flip back armrest.....	12
2.1	Symbols and labels used on the product.....	5	5.7	Set leg rests and footplates.....	13
2.2	Safety: Temperature.....	5	5.8	Pre-set headrest.....	14
2.3	Safety: Moving parts.....	5	5.9	Pre-set fixed / swing away controller.....	15
2.4	Safety: Choking hazard.....	5	5.10	Check after setup and/or adjustment of wheelchair.....	15
2.5	Safety: General warnings.....	6	6.0	SEATING POSITIONING ACCESSORIES.....	16
2.6	Safety: Accessory trays.....	6	6.1	Lap strap / seating positioning belt.....	16
2.7	Safety: Stability.....	6	7.0	USING THE SEATING SYSTEM.....	17
3.0	GENERAL DESCRIPTION.....	7	7.1	Making a transfer.....	17
3.1	Maximum user weight.....	7	7.2	Curves.....	18
4.0	WARNINGS FOR COMPONENTS AND OPTIONS.....	8	7.3	Breaking and Emergency stop.....	18
4.1	Armrests.....	8	7.4	Driving on a slope.....	18
4.2	Cushions.....	8	7.5	Powered seating options.....	19
4.3	Fasteners.....	8	7.6	Electric standing function.....	20
4.4	Footplate and footrests.....	8	7.7	Seat memory position.....	20
4.5	Positioning belts.....	8	7.8	Standing function.....	22
4.6	Push handles.....	8	8.0	MAINTENANCE AND CLEANING.....	24
4.7	Seating systems.....	8	8.1	General maintenance.....	24
4.8	Upholstery fabric.....	8	8.2	Cleaning your seating system.....	25
4.9	Wiring and connectors.....	8	8.3	Hygiene measures when being re-used.....	25
4.10	Assignable controls.....	8	8.4	General cleaning instructions.....	25
4.11	Power seating safety.....	9	8.5	Cleaning accessories.....	25
4.12	Power recline.....	9	8.6	Medium to long term storage.....	25
4.13	Power leg rest.....	9	8.7	Maintenance and inspection schedule.....	26
4.14	Double tilt module.....	9	9.0	TECHNICAL SPECIFICATIONS: APPLICABLE NORMS / STANDARDS.....	26
4.15	Swing away joystick arm.....	9	10.0	SUNRISE LIMITED WARRANTY.....	27
4.16	Motor locks.....	9			
4.17	On/Off switch.....	9			
4.18	Motor and suspension springs.....	9			
4.19	Standing position.....	10			
4.20	Transit.....	10			

Congratulations on choosing a Sunrise Medical wheelchair. Our high quality mobility products are designed to enhance your independence and make your everyday life easier.

As a part of our ongoing product improvement initiative, Sunrise Medical reserves the right to change specifications and design without notice. Further, not all features and options offered are compatible with all configurations of the wheelchair.



All dimensions are approximate and may be subject to change. The intended lifetime of the wheelchair is five (5) years. Please DO NOT use or fit any third party components to the wheelchair unless they are officially approved by Sunrise Medical.

**1.1 This user manual**

This user manual will help you to use and maintain your wheelchair safely. This entire user manual for this wheelchair consists of four booklets:

- The general wheelchair user manual
- The user manual for the seating system (this booklet)
- The user manual for the controller
- The user manual for the battery charger

When necessary, this seating user manual refers to other manuals as shown below:

-  General manual: Refers to the general user manual for the wheelchair.
-  Controller: Refers to the user manual for the controller.
-  Battery charger: Refers to the user manual for the battery charger.



**Do not use your wheelchair until this entire manual (all booklets) has been read and understood!**

If one of the user manuals was not included with your wheelchair, please contact your Sunrise Medical authorized dealer immediately.

**1.2 For further information**

Please contact your Sunrise Medical authorized dealer if you have any questions regarding the use, maintenance or safety of your wheelchair. In case there is no authorized dealer in your area or you have any questions, contact Sunrise Medical either in writing or by telephone. For information about product safety notices and product recalls, go to [www.SunriseMedical.com](http://www.SunriseMedical.com)

**1.3 Symbols used in this manual**

-  **DANGER!**  
Potential risk of serious injury or death
-  **WARNING!**  
Potential risk of injury
-  **CAUTION!**  
Potential damage to equipment
- NOTE:**  
General user advice

Not following these instructions may result in physical injury, damage to the product, or damage to the environment!

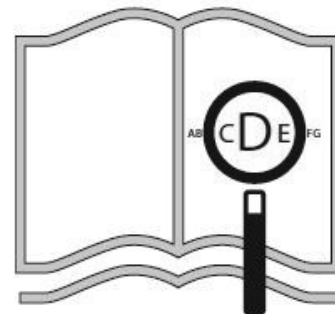

If you are visually impaired, this document can be viewed in PDF format at [www.SunriseMedical.com](http://www.SunriseMedical.com)



## 2.0 SAFETY

Follow the instructions carefully next to these warning symbols! Not paying careful attention to these instructions could result in physical injury or damage to the wheelchair or the environment. Wherever possible, safety information is provided in the relevant chapter.

### 2.1 Symbols and labels used on the product

The signs, symbols, and instructions affixed to the wheelchair comprise part of the safety facilities. They must never be covered or removed. They must remain present and clearly legible throughout the entire lifespan of the wheelchair.

Replace or repair all illegible or damaged signs, symbols, and instructions immediately. Please contact your Sunrise Medical authorized dealer for assistance.

- Fig. 2.1: Warning – Danger of finger entrapment (pinch point).
- Fig. 2.2: Warning – Ensure that the seat interface quick release is screwed in tight before using your wheelchair, especially on a slope.
- Fig. 2.3: Warning – Do not drive your wheelchair on a slope with the backrest reclined.
- Fig. 2.4: Warning – Maximum user weight for the wheelchair.

### 2.2 Safety: Temperature

#### **WARNING!**

1. Avoid physical contact with the wheelchair's motors at all times. Motors are continuously in motion during use and can reach high temperatures. After use, the motors will cool down slowly. Physical contact could cause burns. Allow motors to cool down for at least 30 minutes after use before any physical contact and/or service.
2. If you do not use the wheelchair, ensure that it is not exposed to direct sunlight for lengthy periods of time. Certain parts of the wheelchair, such as the seat, the back, and the armrests can become hot if they have been exposed to full sunlight for too long. This may cause burns or allergic reactions to the skin.

### 2.3 Safety: Moving parts

#### **DANGER!**

A wheelchair has moving and rotating parts. Contact with moving parts may result in serious physical injury or damage to the wheelchair. Contact with the moving parts of the wheelchair should be avoided. (Fig. 2.5)

1. Wheels (turning and caster)
2. Powered tilt in space adjustment
3. Powered seat lift option
4. Powered recline adjustment
5. Swing-away bracket of the controller
6. Power elevating leg rests

### 2.4 Safety: Choking hazard

#### **DANGER!**

This mobility aid uses small parts which under certain circumstances may present a choking hazard to young children.



Fig. 2.1



Fig. 2.2

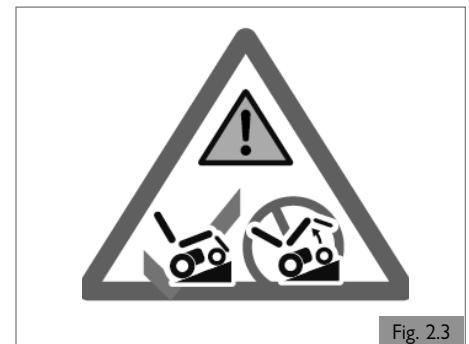

Fig. 2.3

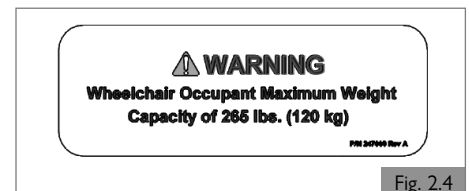

Fig. 2.4

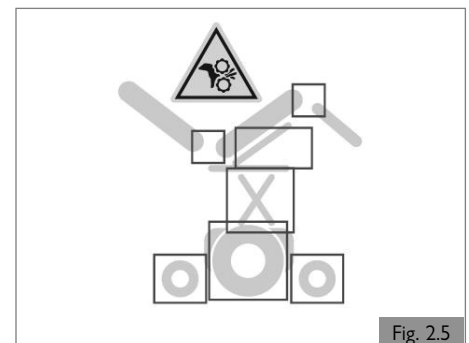

Fig. 2.5

**2.5 Safety: General warnings****⚠ DANGER!**

1. Always ensure that you are able to operate all controls from a comfortable position. Paying attention to your posture is essential to ensure your continued comfort and well being.
2. Always ensure that you can be seen clearly. Use the lights, especially if you intend using your seating system in poor light.
3. This seating system has been set up to match the needs of a particular user. If used by another user, then it may need to be adjusted.
4. Do not let children or others use your seating system.
5. Avoid spilling liquids onto the controller or its connections. Especially hot, sticky, sugary, or corrosive liquids. Such contamination may compromise the safe operation of the control system and damage the seating system upholstery.

**⚠ WARNING!**

DO NOT use any wheelchair that has been involved in a motor vehicle accident. A sudden stop and/or collision may structurally damage your wheelchair. There may have been a change to the structure of the chair, and/or damaged or broken some of the components. Wheelchairs involved in sudden stops should be inspected for possible failures in frame and/or components. Frame damage may be represented by but not limited to: visual cracks, dents, metal distortion, bends, or damage to the seating mounting. If the chair no longer drives straight, it could be damaged. If the wheelchair has been involved in an accident, discontinue use immediately and contact your Sunrise Medical authorized dealer for a thorough inspection. If damage is questionable or if there is concern regarding the condition of the chair, Sunrise Medical recommends replacement of the chair.

Wheelchairs involved in collisions should be replaced.

**Note: The warranty is void on any wheelchair that is involved in a collision.**

**⚠ CAUTION!****2.5.1 Safety: User****⚠ DANGER!**

1. Every seating system is different.
2. Take the time to learn the feel of this system before you begin riding.
3. Be aware that you must develop your own methods for the safe use of this system that are best suited to your level of function and ability.
4. Have someone help you practice bending, reaching, and transfers until you learn how to do them safely.
5. Never try a new maneuver on your own unless you are sure it is safe.
6. Get to know the areas where you plan to use your system. Look for hazards and learn how to avoid them.
7. Always wear a positioning strap.
8. Do not use a seating system if the joystick does not spring back to the neutral position.
9. Do not use your seating system if the joystick boot is ripped or damaged.
10. Do not try to tip this seating system without an attendant present.
11. Do not allow additional riders; the system may become unstable.

**2.5.2 Safety: User and attendants****⚠ DANGER!**

1. When transferring the user in or out of the seating system, never use the footplate as a platform.
2. Do not lift this seating system by any parts that are removable. Doing so may result in damage to the seating system or injury to the user.
3. Never try to stop or slow this seating system with the wheel locks (if applicable). Wheel locks are designed to prevent the system from moving when stopped. They are not brakes.
4. Always keep your hands and body parts clear of moving parts to help prevent injuries.

**2.5.3 Safety: Attendants****⚠ DANGER!**

Ensure you heed all warnings and follow all instructions in each section of this manual. Warnings that apply to the user also apply to you.

1. Do not stand or sit on any portion of this seating system.
2. You need to work with the user, and the user's doctor, nurse, or therapist, to develop safe methods best suited to your abilities and those of the user.
3. To manually push the system you must release the motor brakes.
  - a. Do not engage or disengage motor brakes unless power to the system is off.
  - b. Ensure you have full control over the system when you release the motor brakes. When you do so the system will not have brakes.
  - c. Ensure the system is on level ground before you release the motor brakes.
4. Check to ensure push handle grips will not rotate or slip off.

**2.5.4 Safety: Attendant control****⚠ DANGER!**

Ensure you always have comfortable access to the controls while the chair is moving, and ensure that the controller is fixed securely to the chair.

1. Set the speed of the attendant control to a speed that you can comfortably follow.
2. Always turn off the power to the controller when leaving the user in the chair.

**2.6 Safety: Accessory Trays****Safety: Vent tray****⚠ DANGER!**

Using a vent tray will affect the stability and overall weight of your wheelchair.

1. Ensure that the batteries and the ventilator are securely fastened to the tray before use.
2. Familiarize yourself with the increased size of the wheelchair before driving to prevent potential collisions.
3. When activating the recline backrest ensure that the area around the vent tray is clear.
4. Be aware that the vent tray assembly can cause a finger trap hazard when the backrest is reclined.
5. The vent tray is not designed to hold anything other than the vent unit and its batteries. It is not designed to hold an oxygen bottle, etc. Use of these items may cause your wheelchair to become unstable.
6. The vent tray must be placed and maintained by a Sunrise Medical authorized dealer.

**Safety: Swing away tray****⚠ DANGER!**

1. The maximum load allowed for the tray is 5.5 lbs (2.5 kg).
2. Do not overload the tray, this could cause the tray to break or could cause the chair to become unstable.
3. Do not leave lit cigarettes or other heat sources on the tray as this could cause the tray to deform and mark.
4. Ensure that all extremities and clothing are clear when positioning the tray for use.

**2.7 Safety: Stability****⚠ WARNING!**

1. Removing the batteries may cause the chair to become unstable causing it to tip backwards.
2. Only remove the batteries while the chair is on the ground.
3. Do not remove the batteries while the chair is on a lift table or on any other elevated surface.

## 3.0 GENERAL DESCRIPTION

### General description

This wheelchair is equipped with the Q700-UP M seating system. The Q700-UP M seating system provides excellent support for the head, torso, arms, and legs. Optimal body support ensures maximum independence for the wheel chair user.

The wheelchair should be adjusted by a qualified specialist. Incorrect settings may have negative consequences for the user.

**INTENDED USE:** The Sunrise Medical Quickie Q700-UP M power wheelchairs provide seating standing function. This chair is intended for patients with spinal cord injury, spina bifida, cerebral palsy, multiple sclerosis, muscular dystrophy, polio, rheumatism, and other diseases and conditions which limit a patient's mobility.

**INDICATIONS FOR USE:** The Sunrise Medical Quickie Q700-UP M power wheelchairs are battery operated devices that are indicated for medical purposes to provide mobility and repositioning of the user, including a standing feature.

#### MAIN Components (Fig.3.1)

- |                  |                  |                              |
|------------------|------------------|------------------------------|
| 1. Headrest      | 6. Footrest      | 11. Battery Box (under seat) |
| 2. Armrest       | 7. Front Casters | 12. Standing Actuators       |
| 3. Joystick      | 8. Drive Wheels  | 13. Backrest                 |
| 4. Seat Cushion  | 9. Rear Casters  |                              |
| 5. Knee Fixation | 10. Motors       |                              |

### 3.1 Maximum user weight

#### **The overall maximum user weight shall not exceed:**

Q700-UP M - 265 lbs (120 kg)

#### **⚠ WARNING!**

Exceeding the weight capacities could lead to injury and/or permanent damage to the equipment.

**NOTE** — Exceeding the weight limit will void the warranty.



## 4.0 WARNINGS: COMPONENTS AND OPTIONS

**⚠ WARNING!**

If you use parts or make changes not authorized by Sunrise Medical it may create a safety hazard and will void the warranty.

**4.1 Armrests****⚠ WARNING!**

1. Armrests will not bear the weight of the user.
2. NEVER lift this system by its armrests. They may come loose or break.
3. When transferring the user in or out of the seating system, never use the armrest as a means of support.

**4.2 Cushions****⚠ WARNING!**

1. Standard foam cushions and other body supports are not designed for the relief of pressure.
2. If you suffer from pressure sores, or if you are at risk that they will occur, you may need a special seating system or a device that will help control your posture.
3. Consult your health care provider to find out if you need such a device for your comfort and health.

**4.3 Fasteners****⚠ DANGER!**

Many of the screws, bolts, and nuts on this system are special high-strength fasteners. Use of improper fasteners may cause your system to fail.

1. Only use fasteners provided by Sunrise Medical.
2. If fasteners become loose, tighten them immediately.
3. Do not over- or under tighten fasteners as this can cause damage to your system or its components.
4. Do not reuse fasteners.

**4.4 Footplate and footrests****⚠ DANGER!**

1. At the lowest point, footrests should be at least 2-in (51 mm) off the ground. If set too LOW, they may “hang up” on obstacles you can expect to find in normal use. This may cause the system to stop suddenly and tip forward.
2. To avoid a trip or fall when you transfer:
  - a. Ensure your feet do not “hang up” or get caught in the space between the footrests.
  - b. Avoid putting weight on the footrests, as the system may tip forward.
  - c. Remove or swing the footrests out of the way, if possible.
3. The footrest should always be in the down position when operating the system.
4. Never lift this system by the footrests. Footrests detach and will not bear the weight of this system. Lift this system only by non-detachable parts of the main frame.

**4.5 Positioning belts****⚠ DANGER!**

The positioning belt is predominately used to support your posture. It can also be used to limit slipping and/or sliding that you might experience when the system is in motion. The positioning belt is not a transit rated safety belt and should not be used in the place of a seat belt while being transported in a motor vehicle. Improper use of positioning belts may cause severe injury or death. If you use a positioning belt, ensure you follow the recommendations in this section:

1. Ensure the rider does not slide down in the seating system seat. If this occurs, the rider may suffer chest compression or suffocate due to pressure from the belts.
2. The belts must be snug, but must not be so tight that they interfere with breathing. You should be able to slide your open hand, flat, between the belt and the rider.
3. A pelvic wedge or a similar device can help keep the rider from sliding down in the seat. Consult with the rider's doctor, nurse, or therapist to find out if the rider needs such a device.

4. Use positioning belts only with a rider who can cooperate. Ensure the rider or attendant can easily remove the belts in case of emergency.
5. NEVER use positioning belts:
  - a. As a patient restraint. A restraint requires a doctor's order.
  - b. On a rider who is comatose or agitated.
  - c. As a motor vehicle restraint. In an accident or sudden stop the rider may be thrown from the system. Seating system seat belts will not prevent this, and further injury may result from the belts or straps.

If you fail to heed these warnings, damage to your system, a fall, tip-over, or loss of control may occur and cause severe injury to the rider or others.

**4.6 Push handles****⚠ DANGER!**

1. Push handles provide secure points for an attendant to propel and control the system. This helps to prevent a fall or tip-over.
2. Check to ensure push handle grips will not rotate or slip off.

**4.7 Seating systems****⚠ DANGER!**

1. Use of a seating system not approved by Sunrise Medical may affect or interfere with other parts of the system.
2. Never change the seating system unless you consult your Sunrise Medical authorized dealer first.
3. Never raise your seating system to a height of more than 19-in (482 mm) (measuring from the front of the seat pan to the floor) with all actuators in their home position.

**4.8 Upholstery fabric****⚠ DANGER!**

1. Replace worn or torn fabric of the seat cushion and/or seat back as soon as possible. Worn or torn fabrics may increase the potential for a fire hazard.
2. Fabric will deteriorate with age and use. Look for fraying, thin spots, or stretching of fabric at rivet holes. Replace fabric as required.
3. Be aware that washing may reduce flame retardation qualities of the fabric.

**4.9 Wiring and connectors****⚠ WARNING!**

Never pull on cables directly. This can result in wires breaking inside the connector or harness. To remove a plug or connector, always grasp the plug or connector itself.

**4.10 Assignable controls****⚠ DANGER!**

It is possible to assign a function to an input control (buttons, jacks) to your seating system. If controls have been assigned to perform a dual or alternate function ensure you know what each control operates. Please contact your Sunrise Medical authorized dealer or the Sunrise Medical technical service department if you do not receive this information. Failure to do so may result in damage and/or injury.



## 4.0 WARNINGS: COMPONENTS AND OPTIONS

### 4.11 Power seating safety

#### DANGER!

1. Operation
  - a. While driving this seating system in the reclined, elevated, tilted, or standing position use caution.
  - b. DO NOT attempt to operate any power seating option while positioned on an incline.
  - c. DO NOT attempt to operate any power seating option while this seating system is in motion.
  - d. DO NOT attempt to operate the power seating options around children.
  - e. Through programming it is possible to reverse the direction of all powered seating functions. Ensure you know which direction your seat is going to move before operating.
2. Reduced Speed Driving
  - a. This power system is designed to automatically reduce the maximum driving speed to a reduced speed mode when certain power seating limits are reached.
  - b. Depending on the configuration of the chair there might be multiple reduced speeds. Please discuss the multiple reduced speeds with your Sunrise Medical authorized dealer.
  - c. Before operating your chair in reduced and/or creep speed, read all warnings and guidelines related to this feature. They will help in understanding how to reduce the risk of a fall or tip-over and how to identify environmental conditions that could affect your safety when driving while the chair is in reduced and/or creep speed.
  - d. When driving indoors or outdoors, in creep mode, it should only be used on flat, level, and hardscape surfaces.
  - e. Driving in creep mode should never be attempted on uneven terrain such as: gravel, grass, bumpy surfaces, uneven sidewalks, or hills.
  - f. NEVER raise the seat when the chair is being operated in the proximity of any of the terrain types listed above, or on any uneven surface.
3. Pinch Points  
Pinch points may occur when operating the powered seating options on this system. Ensure all hands and body parts are clear of all power seating components that may result in pinch points before operating them.
4. Tilting Power Base with Push Handles  
Do not attempt to tilt power wheelchairs by pulling down on the push handles. Power wheelchairs have heavy bases. As such, attempting to tilt a power seating system to traverse obstacles can damage components in the seating system and/or modular actuators.
5. Remain Clear During Power Accessory Operation  
Please stay clear of any powered actuator while the component is in motion. Sunrise Medical power mechanisms move over large ranges of travel. Users should be aware of their surroundings while components are in motion.
6. Maximum User Weight  
Do not exceed the weight capacity for your specific system/seating system configuration. Doing so could result in premature failure or injury.
7. Latch Mode
  - a. While operating any power seating function in latched mode use caution. In latch mode, powered seating will not stop until a reverse command is performed or the end of travel is met.
  - b. Please consult with your Sunrise Medical authorized dealer to receive training before using latch mode. Failure to do so may result in potential serious injury

### 4.12 Power recline

#### DANGER!

1. **Trap Point (pinch point)**  
Avoid putting hands or fingers near the power recline mechanism while in operation.
2. **Weight Capacity**  
The maximum user weight capacity for the power recline is up to 265 lbs (120 kg). Exceeding this weight capacity could lead to injury and/or permanent damage to the equipment.

### 4.13 Power leg rest

#### DANGER!

The power leg rest accessory has a maximum user weight capacity of up to 265 lbs (120 kg) depending on your system configuration. Never exceed this capacity while operating the powered actuators or wheelchair.

### 4.14 Double tilt module

#### DANGER!

1. **Trap point (pinch point)**  
Avoid putting hands, fingers, clothing items, or letting children near the seating system when the double tilt mechanism is in operation.
2. **Weight capacity**  
The powered lift and/or lift/tilt modular accessory for this system has a maximum user weight capacity of up to 265 lbs (120 kg). Never exceed this capacity while operating the powered actuator.

### 4.15 Swing away joystick arm

#### DANGER!

Before adjusting the swing away arm, switch off the controller to avoid accidental displacement of the joystick which would cause unwanted movement of your wheelchair. Be aware that the width of your chair may have increased and you may not be able to go through certain obstacles.

#### DANGER!

1. Only operate the wheelchair at a low and maneuverable speed when the parallel swing away is in use.
2. When transferring to and from the wheelchair, do not use the remote as a means of support.
3. Do not hang any items on or over the parallel swing away remote assembly as this could damage the swing away mechanism.

Note: Hanging items on/near the joystick may cause unwanted movement and potential of serious injury or death!

### 4.16 Motor locks

#### WARNING!

1. Do not engage or disengage motor locks unless power to the chair is off.
2. Be aware that the chair will not have brakes when motor locks are in the free-wheel position.
3. Ensure that the person pushing the chair has full control when motor locks are disengaged.
4. Ensure that the chair is on level ground when motor locks are disengaged.

### 4.17 On/Off switch

#### WARNING!

1. Only use the ON/OFF switch to stop the chair in an emergency. This will result in an abrupt stop, and may cause you to fall.
2. To slow your chair to a stop, return the joystick to neutral.

### 4.18 Motor and suspension springs

#### WARNING!

The motor springs and suspension springs are set to factory defaults when the chair is manufactured. These springs should not need to be adjusted and/or detached from the chair. Adjusting these springs could cause instability.

#### For the safety of the user and stability of the chair:

1. NEVER use a spanner wrench to adjust the springs on this chair.
2. DO NOT remove the motor or suspension springs.
3. If the springs need replacing, contact Sunrise Medical Customer Service for parts and service information.

4.19 Standing position

**⚠ WARNING!**

1. Elevating to a standing position and operation in standing position must only be done on a flat surface. When the chair is in elevated position, never reach out from the chair, due the higher tipping risk.
2. The operation of the standing function (and other predefined seating positions) will cause multiple actuators to operate simultaneously.
3. If the seating system operates unintentionally or erratically immediately switch off the system with the On/Off button.

4.20 Transit

**⚠ DANGER!**

Important Transit notes for the chair:

4. If possible and feasible, the rider should transfer to the (OEM) Original Equipment Manufacturer vehicle seat and use the vehicle restraint.
5. If the seating system is used for transport, it must be used in a forward-facing seating position during travel in a motor vehicle.
6. The recommended clear zones for wheelchair seated occupants restrained by both pelvic and upper-torso belt(s) and only by a pelvic belt are shown in the diagrams (Fig. 4.1 and 4.2) and described below. Frontal Clear Zones (FCZ) need to be larger when upper torso belt(s) are not used. The Rear Clear Zone of 16-in (40.5 cm) is measured from the rearmost point on an occupant's head. The Frontal Clear zone is measured from the front most point of an occupant's head and is 26-in (66 cm) with pelvic and upper-torso belt(s) and 37-in (94 cm) with only a pelvic belt. The frontal clear zone may not be achievable for wheelchair-seated drivers.
7. The estimated seated height (HHT) from the ground or floor to the top of the wheelchair-seated occupant's head ranges from approximately 47-in (119 cm) for a small adult female to about 61-in (155 cm) for a tall adult male (Fig. 4.2).
8. The rider must not weigh more than 265 lbs (120 kg).
9. Attach WTORS to securement points in accordance with the manufacturer's instructions and SAE J2249.
10. Ensure hip guides are mounted and are locked in place.
11. Use only Wheelchair Tie-down and Occupant Restraint Systems (WTORS) which meet the requirements of SAE J2249 Recommended Practice– Wheelchair Tie-down and Occupant Restraint Systems For Use in Motor Vehicles. Do not use WTORS designed to rely on the wheelchair structure to transfer occupant restraint loads to the vehicle.
12. In order to reduce the potential of injury to vehicle occupants, wheelchair-mounted accessories, such as trays and respiratory equipment, should be removed from the seating and wheelchair and secured separately.
13. Postural supports and positioning devices should not be relied on for occupant restraint.
14. Do not alter or substitute wheelchair frame parts, components, or seating.
15. Sudden stops or impacts can structurally damage your system. Chairs involved in such incidents should be replaced.

Important Transit notes for Occupant restraints:

16. Attach occupant restraints in accordance with the manufacturer's instructions and SAE J2249.
17. Both pelvic and upper torso restraint belts must be used to restrain the occupant to reduce the possibility of head and chest impacts with the vehicle components and serious risk of injury to the user and other vehicle occupants (Fig. 4.3).
18. The upper torso restraint belt should be mounted to the vehicle (B) pillar. Failure to do so will increase the risk of serious abdominal injuries to the user (Fig. 4.3).
19. A head restraint suitable for transportation must be fitted and suitably positioned at all times during transportation.
20. The pelvic restraint belt (C) must be worn low across the front of the pelvis so that the angle of the pelvic belt is within the preferred zone of 30 to 75 degrees to the horizontal (Fig. 4.3).
21. A steeper (greater) angle within the preferred zone is desirable, closer to, but not exceeding 75 degrees (Fig.4.5).
22. The upper torso restraint belt (A) must fit over the shoulder and across the chest (Fig. 4.3).
23. Restraint belts must be adjusted as tightly as possible consistent with user comfort, and should not constrict breathing (Fig. 4.4).

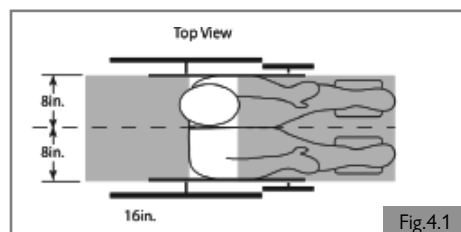

Fig.4.1

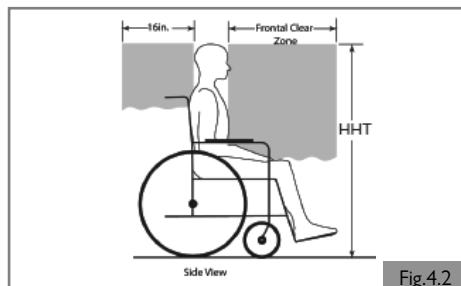

Fig.4.2

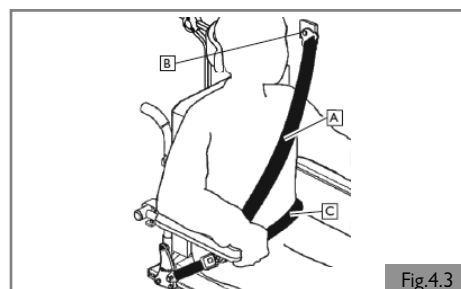

Fig.4.3

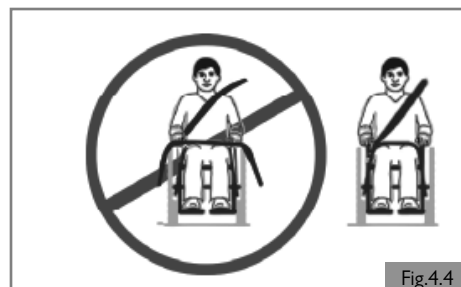

Fig.4.4

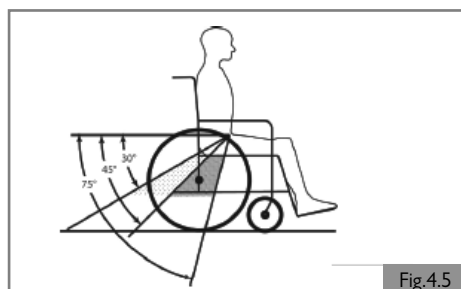

Fig.4.5

## 5.0 SETTING UP THE WHEELCHAIR

The average wheelchair user does not exist. This is why Sunrise Medical wheelchairs can be adjusted according to specific needs of the user.

Pre-settings are carried out once, the first time the wheelchair is going to be used. They must be executed by a Sunrise Medical authorized dealer, unless explicitly stated otherwise.

### Tool and calibration marks

An M5 Allen key is supplied with the seating system. This can be used by a Sunrise Medical authorized dealer for adjusting all of the seating system settings.

### CAUTION!

There are calibration marks on various parts of the seating system. The factory settings are indicated.

### Center of gravity

### DANGER!

Adjusting the center of gravity on a powered wheelchair is both physically demanding and safety critical. Sunrise Medical strongly recommends that this adjustment is only performed by an authorized dealer approved by Sunrise Medical.

Adjusting C.O.G. influences stability in a standing position. Never adjust the center point of gravity (C.O.G.) on the Q700-UP M without consulting a Sunrise Medical authorized dealer or customer service representative.

### 5.1 Seating system (Fig. 5.1)

The extensive settings with respect to the seating system allow for optimum support of the body. The following setting options are possible:

1. Seat depth and seat width
2. Backrest angle
3. Armrest height
4. Lower leg length
5. Angle of the footplate

### 5.2 Seat height

Depending on the specific circumstances of the user of the wheelchair the seat height can be set. Every optional seat height lays within the maximum safe slope as described in (ISO 7176). Lowering the seat height has a positive influence on the (dynamic) stability.

### WARNING!

Increasing the seat height has a negative effect on dynamic stability.

### 5.3 Set seat depth (Fig. 5.2, Fig. 5.3a, and Fig. 5.3b)

1. Use a 5.0 mm Allen Key.
2. Remove the 2 screws (A) on the bottom of the double tilt module.
3. Remove the two screws (B) from the armrest linkage.
4. The back assembly can now be adjusted.
5. Align the back so it is lined up with a number on the shift piece. Align the end of the armrest bar to the same number and reattach the bolts. (Fig. 5.3a and 5.3b)
6. Add the screws back to the bottom of the double tilt module in the two available holes.

### CAUTION!

When a bigger seat depth is required ensure that the cables are lengthened before the mechanical adjustment takes place.

### DANGER!

We strongly recommend that you contact your Sunrise Medical authorized dealer to adjust the seat depth, because adjusting the seat depth will affect the center of gravity.

### 5.4 Control system program

This wheelchair is equipped with a control system that can be programmed by adjusting settings within the system. This is a specialized job that needs training and can only be adjusted with professional software. It is not possible and not allowed for end users to adjust these settings

### DANGER!

The incorrect setting of the parameters for the control system may result in very dangerous situations. Settings must be made by a Sunrise Medical authorized dealer.

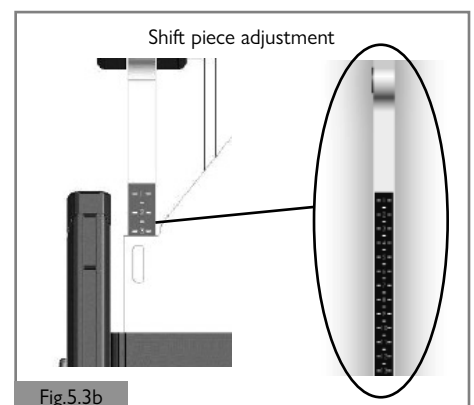
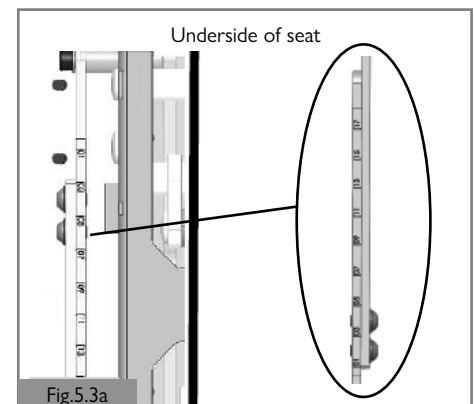
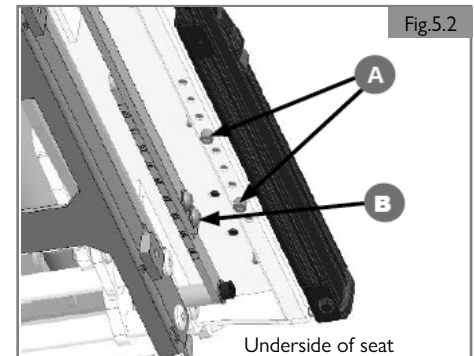
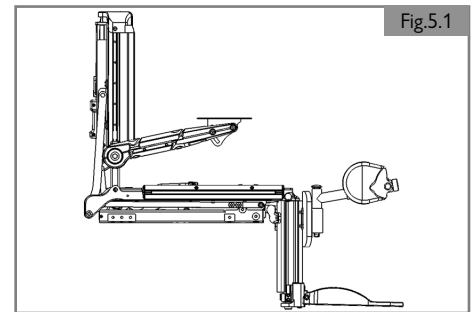

**5.5 Set armrest width**

**Set the armrest width**

1. Remove the two screws (A) using 5mm Allen key (included with chair) on the traversing tube as shown (Fig. 5.4)
2. Move the armrest receiver brackets to the desired position.
3. Attach the screws (A) firmly prior to use.

**5.6 Pre-set reclining flip back armrest**

**Armrest height**

Fine or gross adjustment, it is a two-part process:

**Part 1 (Fig. 5.5)**

4. Loosen (A) in order to adjust (B).

**Part 2 (Fig. 5.6)**

5. Loosen (A) in order to adjust (B).
6. Retighten screws (A-Fig. 5.4 and A-Fig.5.5). See section 8 for specified torque values.

**Armrest pad depth (Fig. 5.7)**

1. Loosen both screws (A) by one turn.
2. Adjust (B) to the desired position.
3. Tighten (A). See section 8 for specified torque values.

**Armrest width adjustment (Fig. 5.8 and 5.9)**

1. Using 8mm hex tool, for M10 to loosen both screws (A) by one turn.
2. Adjust (B) in or out to the desired position.
3. Tighten (A) to 45-55 Nm [398-486 in-lbs].

**⚠ WARNING!**

All screws should be checked periodically for tightness. A loose arm pad could slip down when pressed. See maintenance schedule in Section 8.

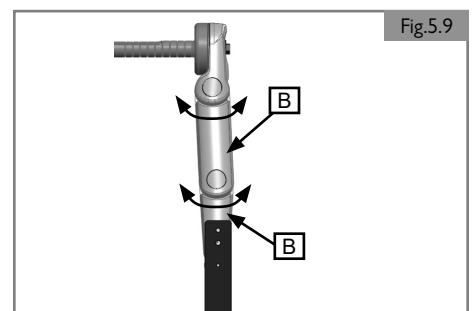
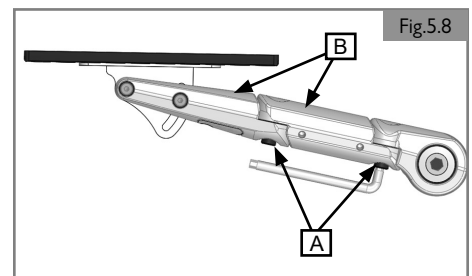
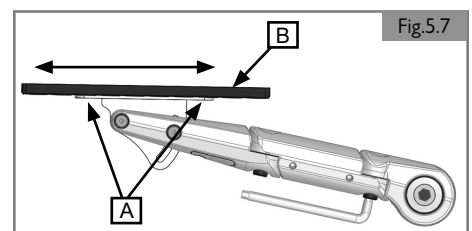
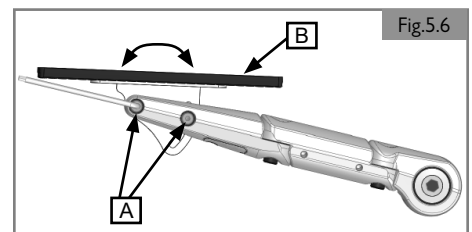
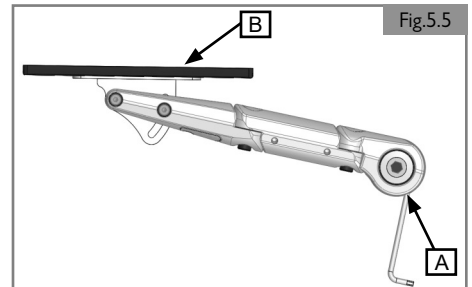
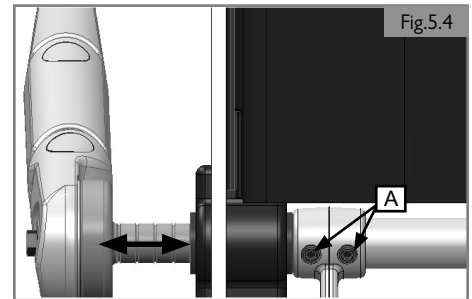

## 5.0 SETTING UP THE WHEELCHAIR

### 5.7 Set leg rests and footplates

#### **WARNING!**

1. Be aware of your environment to ensure you do not injure your legs when leg rests are extended.
2. Always ensure that the leg rests or footplates do not come into contact with the casters before driving the wheelchair.
3. Leg rests are not to be used for lifting or carrying the wheelchair under any circumstances.
4. As with all moving parts be careful not to trap your fingers. (Fig. 5.10)

#### Set footplate height and angle

The power center mount footrest allows angle adjustment from 90° to 180° level to ground and a 7.5-in (190 mm) powered length extension.

The left and right footplate can be adjusted by an angle of +/-5.0° and has a mechanical height range adjustment of 11.8-in to 16.7-in (301 mm to 424 mm) measured from the footplate to the seat pan.

#### Set footplate height

1. Use 5mm Allen key to remove the two bolts (A) on the outside edge of the PCM leg rest. Repeat for the other side. (Fig.5.11 and 5.12)
2. Slide the footplate down to the desired position. The adjustment holes on this side tube are spaced 20mm (0.78-in) from each other with a maximum of 80mm (3.15-in) of additional length.
3. Use 5mm Allen key to tighten the bolts on both sides.

#### Set footplate angle

1. Flip up the footplate so that you can reach the angle setting screw (B). (Fig. 5.13)
2. Use a 4mm Allen key to adjust the bolt in or out depending on the angle required.

#### **WARNING!**

1. After adjustment and with the seat in its normal drive position: Ensure there is a gap of at least 2-in (51 mm) between the floor and the footplate at all times when maneuvering the footplate up or down.
2. Perform this test with the user sitting in the chair loading the leg rest.
3. Using the chair with the leg rest set too low might result in personal injury or damage to the wheelchair and its surroundings.

#### Set footplate width

1. Remove bolt (D) with an Allen key. (Fig. 5.14)
2. Move spacer (E) from inside of footrest to the outer side.
3. Reinsert bolt and tighten securely.
4. Repeat for the other side.

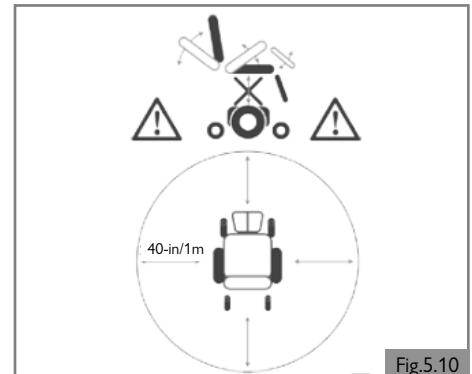

Fig.5.10

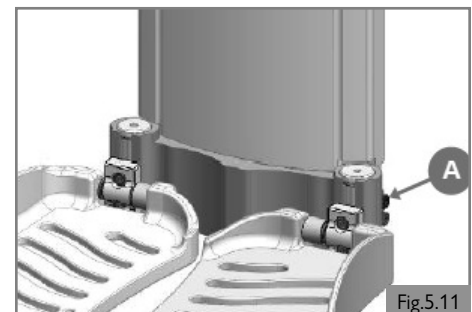

Fig.5.11

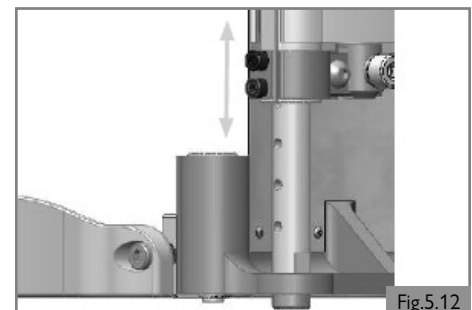

Fig.5.12

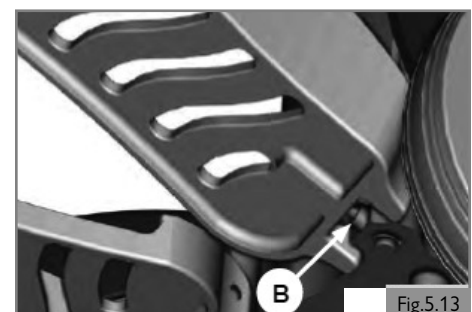

Fig.5.13

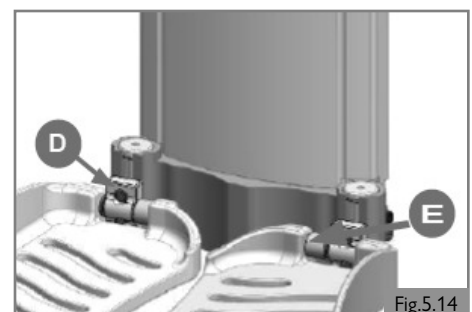

Fig.5.14

**5.8 Pre-set headrest**



1. If a headrest is part of the options selected for the user/chair, never drive the chair without the headrest attached.
2. Never use the chair without a headrest if a person is transported with the chair in a vehicle.

**Headrest height (Fig. 5.15)**

1. Loosen (A) a few turns.
2. Adjust (B) to the desired position.
3. Tighten (A). See section 8 for specified torque values.

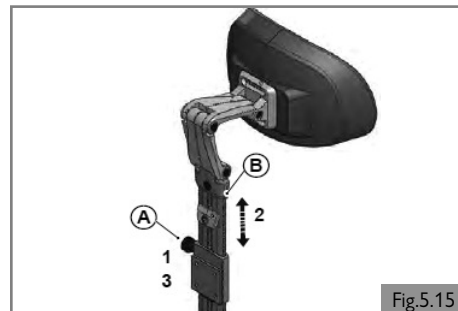

Fig.5.15

**Fixed height setting (Fig. 5.16)**

1. Loosen (C) by one turn.
2. Slide (D) as far down as possible.
3. Tighten (C). See section 8 for specified torque values.

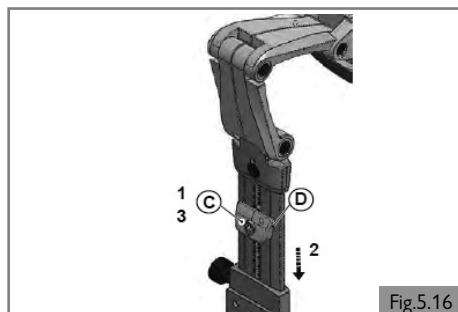

Fig.5.16

**Headrest position (Fig. 5.17)**

1. Loosen (A) by one turn.
2. Adjust (B and C) to the desired position.
3. Tighten (A). See section 8 for specified torque values.

Note: Correct the headrest height and tilt the headrest cushion as required.

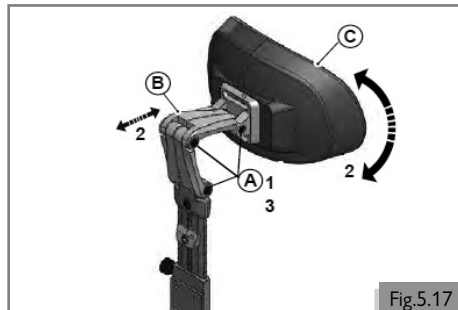

Fig.5.17

**Headrest cushion width (Fig. 5.18)**

1. Loosen (A) by one turn.
2. Adjust (B) to the desired position.
3. Tighten (A). See section 8 for specified torque values.

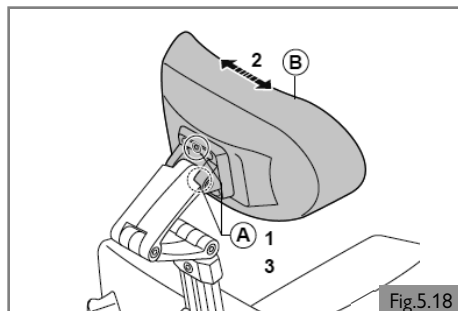

Fig.5.18

## 5.0 SETTING UP THE WHEELCHAIR

### 5.9 Pre-set fixed / swing away controller

#### Bracket depth of the controller (Fig. 5.19)

1. Loosen (A) by one turn.
2. Adjust (B) to the desired position.
3. Tighten (A). See section 8 for specified torque values.

#### Height of the controller (1) (Fig. 5.20)

1. Loosen (A) by one turn.
2. Adjust (C) to the desired position.
3. Tighten (A). See section 8 for specified torque values.

#### Height of the controller (2) (Fig. 5.21)

1. Loosen (D) by one turn.
2. Adjust (B) to the desired position.
3. Tighten (D). See section 8 for specified torque values.

### 5.10 Check after setup and/or adjustment of wheelchair

After the initial setup by the Sunrise Medical authorized dealer or after making any adjustments to the wheelchair a check to confirm that no interferences exist must be completed. Interferences can happen (but not limited to) adjustments to the joystick, armrest, specialty control mounts, leg rest, headrest, etc. After an adjustment has been made, the movement of that device may collide or hinder the operation of another component of the wheelchair. A check must be performed prior to operation of the chair to ensure all moving pieces move freely and through the entire range of motion without coming into contact with another part of the wheelchair.

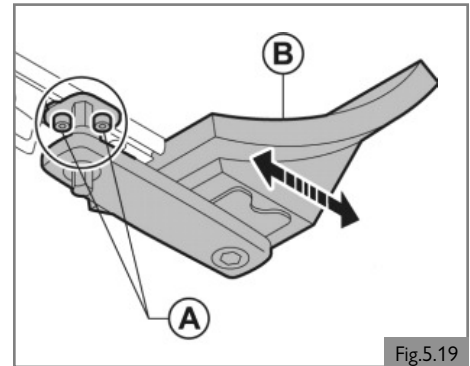

Fig.5.19

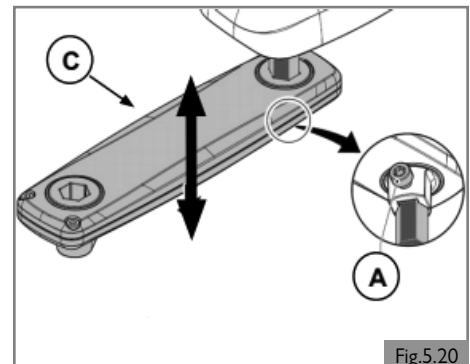

Fig.5.20

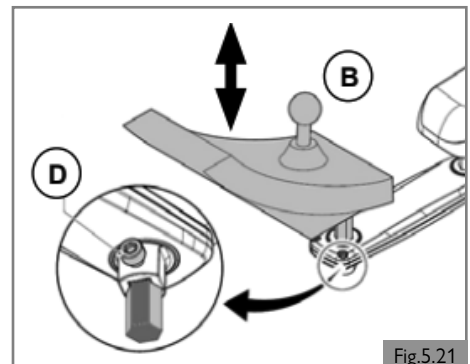

Fig.5.21

## 6.0 SEATING POSITIONING ACCESSORIES

### 6.1 Lap strap / seating positioning belt (Fig. 6.1)

**⚠ DANGER!**

1. This product is only to be used to position a single person in a wheelchair.
2. Lap straps are not suitable for transit purposes. Approved occupant restraint systems must be used.
3. Failure to heed these warnings may result in severe injury or death.
4. Ensure that the carer or attendant is trained in the correct operation of the belts.
5. Untrained carers or attendants may lead to delays, if an emergency situation occurs.

#### Mounting a lap strap / seating positioning belt

1. Feed the bracket ends of the straps under the backrest brace bar as shown, using the lower fixing hole. Ensure that the adjuster buckles can be accessed and the strap (A) is not twisted. (Fig. 6.2)
2. Put a washer on the bolt.
3. Pass the bolt through the lap strap fixing bracket.
4. Put the next washer on to the bolt. (Fig. 6.3)
5. Screw the bolt into the lowest pre-drilled hole in the frame. (B-Fig. 6.2)
6. Tighten using a 5.0mm hex wrench to a torque value of 6.8-7.9 Nm [60-70 in-lbs]. (C-Fig. 6.2)
7. Adjust the lap strap to suit, leaving no more than a hand's width gap for comfort and safety. (Fig. 6.4)
8. The hand clearance should be with the lap strap under normal tension and not allow large gaps or loops. (Fig. 6.4)
9. Generally, the lap strap should be fixed so that the straps sit at an angle of approximately 45° and when correctly adjusted should not allow user to slip down in the seat. (Fig. 6.5)
10. Place the strap loosely across the seat with the opening end of the buckle facing to the right for a left handed person and to the left for a right-handed person.



Fig.6.1

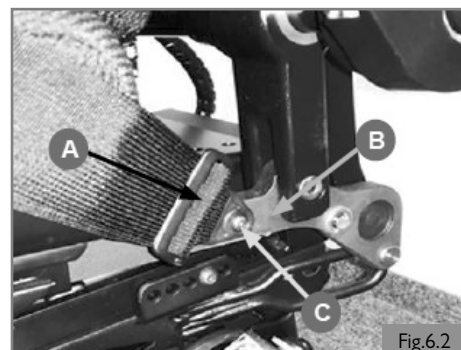

Fig.6.2

#### Positioning a person with a lap strap

**⚠ DANGER!**

1. Always ensure that the lap strap is correctly secured and adjusted prior to use.
2. Too loose a strap could cause the user to slip down and cause serious injury.
3. Check lap strap and securing components at regular intervals for any signs of fray or damage. Replace if necessary.
4. When servicing, check for correct operation of the release buckle and for any signs of wear on the material or plastic brackets.

#### Regular checks/activities

1. As with all positioning components, there is a need for corrective adjustments as the person changes their seating position over time.
2. Check the belts regularly for correct fit, to ensure the safety and comfort of the user.

Note: Contoured Back — Use universal bottom bracket as per recline back method.

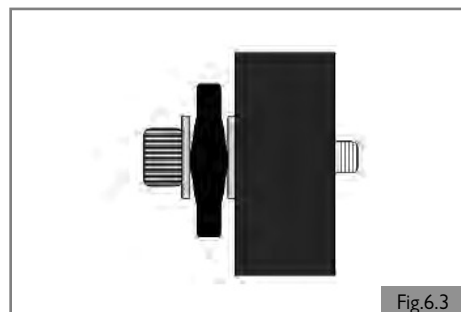

Fig.6.3

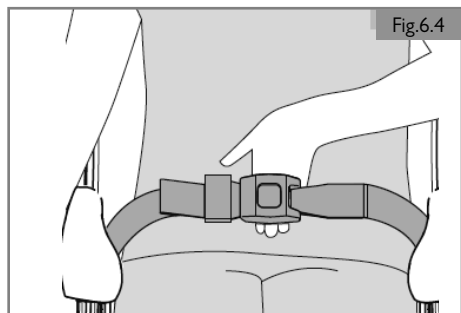

Fig.6.4

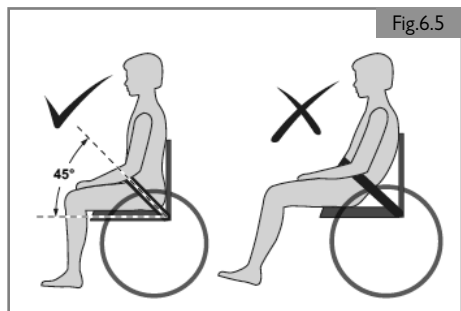

Fig.6.5



## 7.0 USING THE SEATING SYSTEM

### 7.1 Making a transfer

Sunrise Medical recommends that you consult your health care provider for assistance in developing your personal front or side transfer technique to best suit your needs and avoid any personal injury.

#### **⚠ DANGER!**

To prevent a fall:

1. Ensure controller is switched off during transfers to avoid unintentional movement. If you fail to do so you may touch the joystick and cause your system to move when you do not expect it.
2. Ensure that the free wheel switch has been set to 'drive'. (  ) General manual.
3. Rotate the front casters so that they point forward.
4. Work with your health care provider to learn all safe methods for transfers.
5. Ensure motor brakes are engaged. This keeps the system from moving when you transfer.
6. It is dangerous to transfer on your own. It requires good balance and agility. Be aware that there is a point during every transfer when the seating system seat is not below you.
7. Learn how to position your body and how to support yourself during a transfer.
8. Have someone help you until you are sure you can do a safe transfer on your own.
9. Do not stand on the footrest. Putting your full weight on the footrest may lead to wheelchair damage and to hazardous situations, including the wheelchair tipping up.
10. Ensure your feet do not "hang up" or get caught in the space between the footrests.

#### Preparing for a forward transfer

#### **⚠ DANGER!**

Move your wheelchair as close as possible to the seat you intend to transfer into.

#### Remove the front knee fixation

To remove (Fig. 7.1, Fig. 7.2)

1. Press the Red lever (A), on the top of the front knee fixation assembly.
2. Gently lift the assembly up and out of the receiver.

To refit (Fig. 7.1, Fig. 7.2)

1. Press the Red lever (A), on the top of the front knee fixation assembly.
2. Place the lower edge of the tube into the receiver.
3. Push home and release the button.
4. Ensure the assembly is fixed firmly in place.

#### Lower the center mount footplate ( ) R-Net Control System

1. Ensure the area is level and free of obstacles and hazards.
2. Turn the control system ON.
3. Select the powered center mount leg rest.
4. Push the joystick forward until the footplates rest fully on the ground. (Fig. 7.3)
5. Switch the control system OFF before transferring.

#### **⚠ WARNING!**

Be aware that when powered, the area around and underneath the footplate needs to be clear of all personal items and bodily extremities to prevent injury or damage to property.

#### **⚠ CAUTION!**

Once the leg rest is fully in its lowest position do not hold the joystick in its operating position as this could damage the actuator.

#### Side transfer (Fig. 7.4)

1. Perform the above procedure, but also flip back the armrest on the appropriate side for the transfer.

#### **⚠ DANGER!**

Move your system as close as you can to the seat you are transferring to. If possible, use a transfer board. Transfer as far back onto the seat surface as you can. This will reduce the risk that you will miss the seat or fall. On the side you wish to transfer from, flip the armrest all the way up until it goes into its mechanical stop. This frees your space for side transfer. (Fig. 7.4)

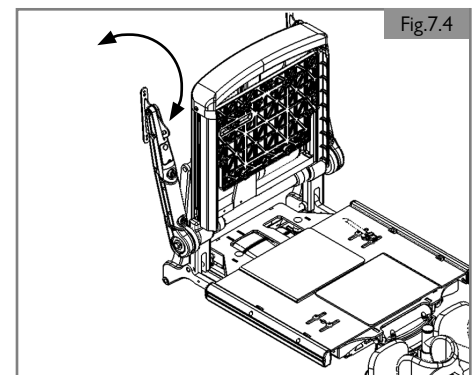
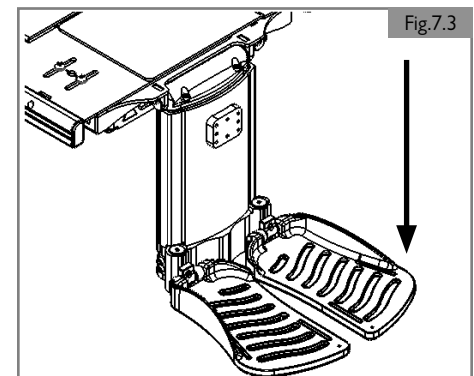
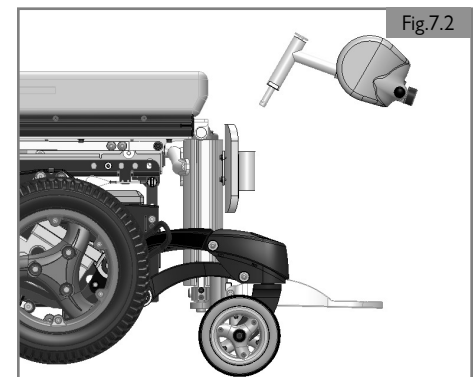
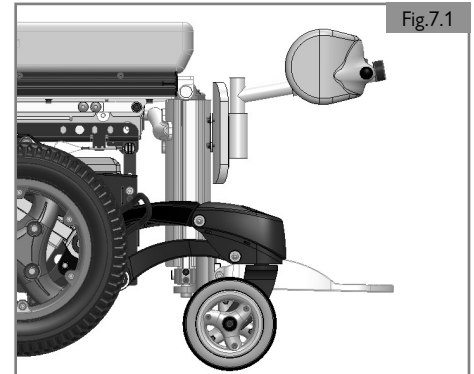

## 7.2 Curves

### DANGER!

Full speed turns should not be attempted. If you need to turn sharply you must reduce your speed with the joystick or speed setting. This is particularly important when traveling across or down a slope. Disregarding this advice could lead to your wheelchair tipping over.

### WARNING!

Use indicators when changing direction.

## 7.3 Breaking and emergency stop

There are three ways to stop your wheelchair:

1. Simplest and safest way to stop the wheelchair is to release the joystick. This will bring the chair to a halt in a controlled manner.
2. Pulling back the joystick will brake the chair abruptly with a fast stop.
3. Switching the control system off while the chair is in motion will also bring the chair to a halt.

### WARNING!

1. Switching the control system off is only to be used in an emergency situation as the stopping action is very abrupt.
2. Never try to stop or slow this seating system with the wheel locks (if applicable). Wheel locks are designed to prevent the system from moving when stopped. They are not brakes.

## 7.4 Driving on a slope

Your wheelchair has been designed and tested to allow its use on slopes or gradients of up to 7.5° for 6 mph and 9° for 8 mph in standard configuration. However, you have the option of adjusting your position with the standing option, powered center mount leg rest, or a combination of these options.

### DANGER!

1. Standing, elevating, tilting, and leg rest adjustments can affect the wheelchair center of gravity. Under certain conditions this might cause instability that could lead to unintentional tipping. It may be necessary to carry out a risk assessment if the wheelchair is adjusted to extremes.
2. Stopping distances on slopes can be significantly longer than on level ground.

### DANGER!

**Do not use the standing feature on slopes or uneven surfaces.**

### DANGER!

1. In certain circumstances your wheelchair could become unstable.
2. Before attempting to climb or descend a slope or a curb, caution should be taken when using weight shift options (e.g. powered recline or standing) of the seat and/or your body for a counter balance weight.
3. To improve stability lean forward when driving uphill, with the seat and back in an upright position.
4. Alternatively sit in an upright position when traveling in a forward, downhill direction and /or recline the seat backwards.
5. We strongly recommend that you return the seat and back to their home positions before attempting to climb or descend a slope. Failure to do this may cause the wheelchair to become unstable.
6. If you are in any doubt about the capabilities of your wheelchair on a slope, then do not attempt to drive up or down the slope/curb; try to find an alternative route.

### Gradients: ascents

### WARNING!

1. When going uphill, keep the chair moving.
2. Steer by carefully moving the joystick forwards making slight Left and Right adjustments as you go.
3. If you have stopped on a hill, you should start slowly.
4. If necessary, lean forward.

### Gradients: descents

On descents, it is important not to let the wheelchair accelerate beyond its normal level of ground speed.

## 7.0 USING THE SEATING SYSTEM

### 7.5 (Powered) seating option

The wheelchair can be equipped by the following mechanical and/or powered options to adjust your seating position. These options can be operated by the user without the use of tools. Powered adjustable seating options (Fig. 7.5 - Fig. 7.7).

How to operate these powered seating options can be found in

() R-Net Control System:

1. Powered tilt function
2. Powered seat elevator
3. Powered backrest recline
4. Powered elevating leg rests
5. Powered standing function

NOTE: During some seating functions, a click will be heard coming from the base of your wheelchair. This is due to the actuation of caster locks, a system that helps stabilize the wheelchair. This noise is a sign that your chair is working properly and is not a sign of concern.

### DANGER!

1. Use of the powered adjustable seating options may influence the stability of the wheelchair.
2. Only use the powered adjustable seating options when the wheelchair is on a flat surface! DO NOT attempt to operate any power seating option while positioned on an incline.
3. Please stay clear of any powered actuator while the component is in motion. Sunrise Medical power mechanisms move over large ranges of travel. Users should be aware of their surroundings while components are in motion.
4. While driving this seating system in the reclined, elevated, or tilted position use caution.
5. Do not attempt to operate the lift or tilt power seating options around children.
6. DO NOT attempt to operate any power seating option while this seating system is in motion.
7. Through programming it is possible to reverse the direction of all powered seating functions. Ensure you know which direction your seat is going to move before operating.
8. Please be aware that the lift/tilt modules present a trap hazard. Ensure that during operation the lift/tilt modules are free from all clothing, hands, feet, and other extremities, to prevent injury.
9. Do not drive on ramps or slopes with the seating in the elevated position. Before attempting to climb or descend a slope, return the wheelchair to a standard seated drive position, with the backrest upright.
10. This power system is designed to automatically reduce the maximum driving speed to a reduced speed mode when certain power seating limits are reached. Depending on the configuration of the chair, there might be multiple reduced speed modes. Talk to your Sunrise Medical authorized dealer about creep speeds for your wheelchair.

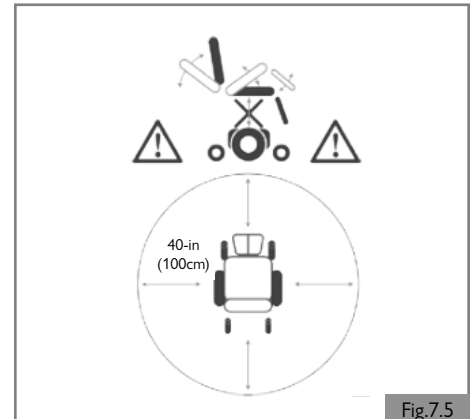

Fig.7.5

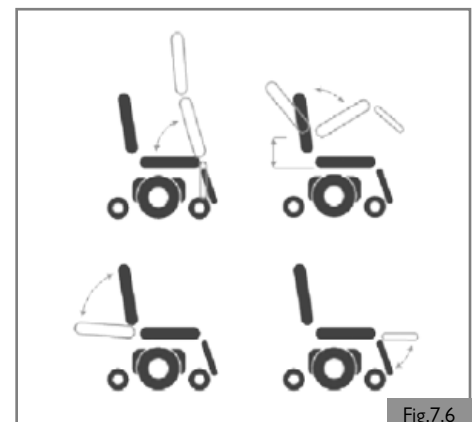

Fig.7.6

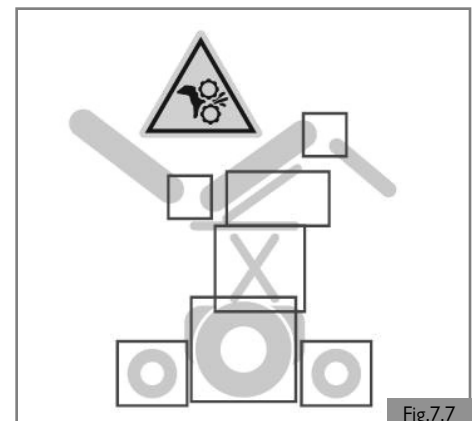

Fig.7.7

### 7.6 Electric standing function

The Quickie Q700-UP M has an electric standing function. This function makes it possible for the user to stand in the wheelchair.

#### ⚠ DANGER!

The use of knee fixation and chest straps are mandatory when using the standing function.

#### ⚠ WARNING!

1. Before using the standing function ensure that the chest belt is secure.
2. Before using the standing function ensure that the front knee fixation is in place.
3. Only use the standing function on a sound and level surface.
4. The standing procedure automatically locks the front and rear caster arm suspension.
5. If the locking procedure fails the chair will automatically stop in a safe position. The seat can always be returned to the normally seated position in any mode. Potential causes could be damage to the harnesses or incorrect assembly placement.

#### ⚠ DANGER!

When the standing, or lie down function is used, the center of gravity is moved away from the original safe position into a raised or retracted position. This can increase the likelihood of tipping over. So only use this seat function on a level floor and drive in the lowest speed. Not doing so could lead to personal injury.

### 7.7 Seat memory position

The control system on the Q700-UP M has up to 6 predefined seat memory positions. Each ordered memory location has a set of factory seat positioning presets:

1. Seated
2. Supine
3. Pressure Relief
4. Forward Tilt
5. Transfer
6. Stand

The seat actuators are all working with a feedback system to track their positions and movements.

This is important:

1. To reach the required memory position.
2. To prevent mechanical clashes of the seat.
3. To operate the actuators especially towards the memory positions in an ergonomic, smooth, and safe way.

All ordered memory positions, if not suitable for the user, can be changed and customized to the needs required. The software takes into account the range of the available mechanical movements and also all safety aspects.

#### 7.7.1 Retrieving a memory seat position (Fig. 7.8 - 7.10)

1. Press the "Mode" button (A) one or more times until a seat icon appears in the LCD control panel display.
2. Move the joystick to the left or right to select a memory seat position:
  - a. Seated
  - b. Supine
  - c. Pressure Relief
  - d. Forward Tilt
  - e. Transfer
  - f. Stand

A seat icon and the memory description or the relevant position are shown in the LCD control panel display.

3. Move and hold the joystick forwards. The seat adjusts to the factory preset position. The movement can be stopped at any time and started again when moving the joystick forward.
4. In any of the 6 memory seat positions moving the joystick backwards brings the seat into the "Seating" memory position. Once the seat has adjusted to the saved position, it stops moving.

Note:

1. Movement of the seat can be stopped at any time by releasing the joystick.
2. During a stop period, another memory position can be selected with a right or left movement of the joystick. After selecting a new memory position, moving the joystick forward will operate the seat into the new selected position.

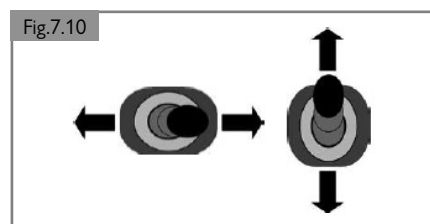
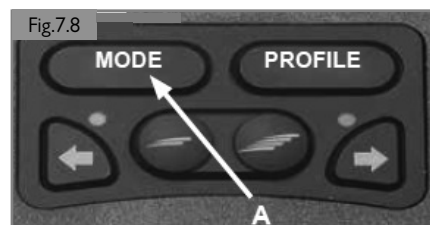

#### 7.7.2 Return to drive mode

Press the "Mode" button one or more times until a standard display image with speed indicator appears in the LCD control panel display.

#### 7.7.3 Saving a new position to memory

1. Remove the rear cover of the backrest and connect a Switch with a 3.5mm Jack to the socket on the CxSM. (Fig. 7.11)
2. Press the "mode" button one or more times until a seat icon appears in the LCD control panel display. (Fig. 7.12)
3. Move the joystick to the left or right to select a memory seat position (Fig. 7.13). A seat icon and the memory description or the relevant position are shown in the LCD control panel display. (Fig. 7.12)
4. Move and hold the joystick forwards (Fig. 7.13). The seat adjusts to the factory preset position. The movement can be stopped at any time and started again when moving the joystick forward.
5. Stop the seat movement where required and select with a left or right joystick movement the seat actuator that needs to be changed.
6. Move the joystick forward or backwards until the required position is reached. Select other actuators if required and move them where needed.
7. Move the joystick left or right until the factory memory position is reached and where the new position shall be programmed in.
8. Press and hold the switch connected to the CxSM (Fig. 7.10) and pull the joystick backwards for 3 seconds until a beep can be heard.
9. Release the joystick and the button. Your new required position is now stored and the actuators will always stop in this new programmed end position.

## 7.0 USING THE SEATING SYSTEM

### 7.7.4 Delete custom programmed memory position (Fig. 7.11 - Fig. 7.14)

1. Remove the rear cover of the backrest and connect a Switch with a 3.5mm Jack to the socket on the CxSM (Complex Seating Module). (A-Fig. 7.11)
2. Press the "Mode" button one or more times until a seat icon appears in the LCD control panel display. (Fig. 7.12)
3. Move the joystick to the left or right to select a memory seat position (Fig. 7.13). A seat icon and the memory description for the relevant position are shown in the LCD control panel display. (Fig. 7.12)
4. Press and hold the Switch connected to the CxSM (Fig.7.14) and pull the joystick backwards for 6 seconds. After 3 seconds you will hear the programming beep and after 6 seconds you will hear a change in the beep sound.
5. As soon as you hear this new sound release the joystick and the button. All memory positions are now set to the factory setting.

### 7.7.5 Return to drive mode

Press the "Mode" button one or more times until a standard display image with speed indicator appears in the LCD control panel display.

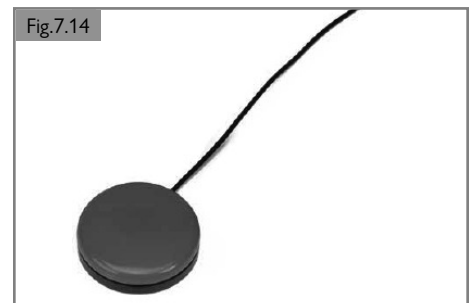
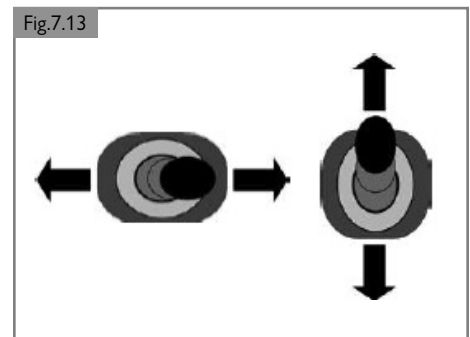

**7.8 Standing function****⚠ DANGER!**

This power chair has an electric standing function. This function makes it possible for the user to stand in the wheelchair.

1. The standing function automatically locks the front and rear caster arm suspension.
2. If the locking procedure fails the chair will automatically stop in a safe position. The seat can be returned to the normally seated position in any mode.

**⚠ WARNING!**

1. Before using the standing function ensure that the front knee fixation is in place.
2. Only use the standing function on a level surface.

**7.8.1 Using the knee fixation****⚠ WARNING!**

Always also use the knee fixation when operating the standing function.

**⚠ DANGER!**

Due to the risk of choking it is extremely hazardous to use the chest strap without using the knee fixation.

**7.8.2 Using a chest strap****⚠ WARNING!**

1. The chest strap may only be assembled and adapted by a Sunrise Medical authorized dealer.
2. Before operating the standing function, the chest strap and the positioning belt must be buckled in accordance with these user instructions.

**⚠ DANGER!**

Due to the risk of choking it is extremely hazardous to use the chest strap without using the knee fixation.

**Setting the height of the chest strap (Fig. 7.15)**

NOTE: A 5mm Hexagon wrench (Allen Key) is required.

**Positioning**

1. Seat the user into the chair in the correct seating position.
2. Loosen the Allen screw to be able to position the chest strap at the desired height.
3. Tighten the Allen screws to a torque value of 6.8-7.9 Nm [5 to 5.8 ft-lbs].

**⚠ DANGER!**

1. To prevent choking hazards the chest strap may not be adjusted too high or too low relative to the user's body.
2. Ensure the rider does not slide in the wheelchair seat. If this occurs, the rider may suffer chest compression or suffocate due to pressure from the chest strap.
3. Never use the chest strap as a patient restraint.
4. Never use the chest strap on a user who is comatose or agitated.

**⚠ CAUTION!**

Ensure the chest strap and/or positioning belt position does not interfere with any other device attached to the wheelchair.



Fig. 7.15

## 7.0 USING THE SEATING SYSTEM

### Adaptation adjustment

1. Seat the user into the wheelchair.
2. Feed the buckle on the chest strap through the loop. (Fig. 7.16)
3. Pull the chest strap so that it fully supports the user's upper body firmly and comfortably. (Fig. 7.17)
4. Ensure that chest strap is not too tight.
5. Close the buckle until a loud click is heard. (Fig. 7.18)
6. The D-Ring facilitates easy adjustment for the user. (Fig. 7.19)
7. Ensure the chest strap fully supports the user and that there is enough room to fit a hand's width between the user and the support. (Fig. 7.20)

### Safety:

**In addition to the chest strap latches, the chest strap incorporates two further safety features that prevent the unintended opening of the belt.**

1. Each of the chest strap latches is secured with an overlaying safety Velcro® strap.
2. In addition, on each side of the chest strap there is a securing strap which is guided through the D-Ring, adding another degree of safety.

### WARNING!

1. Never use the standing function without the knee fixation, chest strap, and positioning belt attached and safely locked.
2. Ensure the rider does not slide in the wheelchair seat. If this occurs, the rider may suffer chest compression or suffocate due to pressure from the supports.
3. Never use positioning supports as a patient restraint.
4. Never use positioning supports on a user who is comatose or agitated.

### Usage:

### DANGER!

1. This product is only to be used to position a single person in a wheelchair.
2. It is not suitable for use as a transportation restraint.
3. Failure to heed these warnings may result in severe injury or death.
4. An unintended opening of the chest strap can result in the user falling forward out of the chair.
5. If it is likely that the movements or cognitive agility of the user could lead to an unintended opening of the chest strap, a caregiver or attendant has to be present at all times when the wheelchair is in use.
6. Ensure that the caregiver or attendant is trained in the correct operation of the belts.
7. Untrained caregivers or attendants may lead to delays, if an emergency situation occurs.

### Regular checks/activities

1. As with all positioning components, there is a need for corrective adjustments as the person changes their seating position over time.
2. Check the belts regularly for correct fit, to ensure the safety and comfort of the user.
3. It is recommended that users carry out the regular exercises prescribed by their health care provider to prevent pressure sores.
4. It is recommended that regular checks are made to monitor skin condition.



Fig. 7.16



Fig. 7.17



Fig. 7.18



Fig. 7.19



Fig. 7.20

The wheelchair's lifespan is dependent on it being well maintained.

For information concerning specific settings, maintenance, or repair work, please contact your Sunrise Medical authorized dealer. Always ensure you mention the model and year of manufacture and identification number provided on the serial number label of the wheelchair when contacting your Sunrise Medical authorized dealer.

### CAUTION!

The wheelchair should be serviced by your Sunrise Medical authorized dealer once a year or, in the case of intensive use, every six months. For a list of approved authorized dealers in your area please contact Sunrise Medical Customer Service.

The contact details of your local Sunrise Medical Service Center can be found on the inside front cover of this booklet.

Website addresses are on the back cover.

## 8.1 General maintenance

### WARNING!

- All fasteners should be checked quarterly for wear, such as loose bolts or broken components.
- Loose fasteners should be re-tightened according to the assembly instructions. See section 8 for specified torque values.  
Note: it will be necessary to use a torque wrench.
- Check all straps monthly for fraying, ripped seams, or other indications of excessive wear damage. Discontinue use if damage is found.
- Chest straps should be replaced at the first indication of damage and/or excessive wear.
- If a broken or loose component is found, discontinue use immediately and contact your Sunrise Medical authorized dealer for replacement.
- Check all Velcro® fastening straps for correct adhesion when pressed together.
- Ensure that any contamination, such as fluff, hair, etc is removed from the Velcro® straps. Such contamination may affect adhesion.

### WARNING!

- If you are in any doubt about the performance requirements of your wheelchair contact your Sunrise Medical authorized dealer.
- After performing any maintenance or repairs on the wheelchair you must ensure that it is functioning correctly before it is used.
- All fasteners must be replaced like for like using the correct length, tensile strength, and materials.
- When replacing self-locking nuts, or nuts/studs secured with a thread locking solution, ensure that a suitable thread locking solution is reapplied to the fastener.

### Daily checks

Perform the daily check routine before driving as described below.

#### Checking seating

- Ensure that all the cushions are in place.
- Ensure that the backrest is correctly fitted and adjusted.

#### Checking connectors and cables

- Ensure that all connectors are securely mated.
- Check the condition of all cables and connectors for damage.

#### Checking clothing for potential entrapment

When operating the wheelchair, ensure that your clothing does not hamper the wheelchair (i.e. too long). Before use, always ensure your clothing or accessories do not come into contact with the wheels and/or other moving and/or rotating parts in which they could become entangled.

#### General daily checks

- Visually inspect the wheelchair to ensure the leg rests, armrests etc. are correctly positioned and attached to the wheelchair and all fasteners are sufficiently tightened.
- Ensure that the seat interface knobs are tight and secure.

- Check to ensure components are not leaking, and components are free from waste/dirt. If one of these items are found, stop using the chair immediately and contact a Sunrise Medical authorized dealer.
- Check to ensure the caster lock is not blocked with waste/dirt.

### Weekly checks

Perform the weekly check routine before driving as described below.

#### Checking connectors and cables

- Ensure that all connectors are securely mated.
- Check the condition of all cables and connectors for damage.

#### Checking controller

- Check the thin rubber gaiter or boot around the base of the joystick shaft for damage or splitting. Check visually only, do not handle the gaiter.
- Ensure that all components of the control system are securely mounted. Do not over-tighten any securing screws.

#### Checking controls

- Switch on the hand control – Do the lights flash? This signifies that there is a fault in the electronic system.
- Operate all of the electric options, including lights and indicators (if fitted) to ensure that they work correctly.
- Drive the wheelchair in each of the drive profiles to ensure the wheelchair performs as it did before.

### General weekly checks

- Check tires for proper inflation level (if applicable).
- Check frame and base for foreign objects and/or obstructions.
- Ensure the knobs that attach the seat frame to the front of the base are not loose.

### Quarterly checks

Perform the quarterly check routine before driving as described below.

- Check all straps for fraying, ripped seams, or other indications of excessive wear damage. Discontinue use if damage is found and contact a Sunrise Medical authorized dealer.
- Check chair for any missing or loose nuts, bolts, and/or fasteners. Contact a Sunrise Medical authorized dealer if found.
- Check wheelchair for any broken components, unusual wear, or other indicators of excessive wear. Discontinue use if damage is found and contact a Sunrise Medical authorized dealer.

### WARNING!

- If you are in any doubt about the performance requirements of your wheelchair contact your Sunrise Medical authorized dealer.
- After performing any maintenance or repairs on the wheelchair you must ensure that it is functioning correctly before it is used.
- A complete inspection, safety check, and service should be made by a Sunrise Medical authorized dealer at least once per year.
- All fasteners must be replaced like for like using the correct length, tensile strength, and materials.
- When replacing self-locking nuts, or nuts/studs secured with a thread locking solution, ensure that a suitable thread locking solution is reapplied to the fastener.
- Check all Velcro® fastening straps for correct adhesion when pressed together.
- Ensure that any contamination, such as fluff, hair, etc. is removed from the Velcro® straps. Such contamination may affect adhesion.
- Do not reuse fasteners.



## 8.0 MAINTENANCE AND CLEANING

### 8.2 Cleaning your seating system

The wheelchair should be wiped over once per week with a slightly damp, not wet, cloth and any fluff or dust that has accumulated around the actuators should be blown or dusted away.

#### CAUTION!

Ensure that you dry all parts of your wheelchair if it becomes wet or damp after cleaning or if it is used in a wet or damp environment.

#### DANGER!

It is important that should the wheelchair be used by more than one person it is cleaned thoroughly to ensure there is no cross infection.

#### 8.2.1 Cleaning and inspection of your seating

#### WARNING!

Tears, dents, wearing, or slacking of upholstery particularly near to metal could result in poor posture or lower levels of comfort and pressure relief.

#### Cleaning instructions for seating

Wash all parts of the covers with a gentle-wash detergent at 100°F (38°C). Spin-dry the covers, but do not dry them in a dryer. Remove all parts of the covers independently of each other and wash them separately. Take out the foam inlays prior to washing and close the Velcro® fasteners!

Where upholstery cannot be removed, clean regularly to prevent build up or soiling. Clean with a damp, soapy cloth. Disinfectants may be used in dilution as specified by their manufacturer. Ensure surfaces are rinsed well with clean water and dried thoroughly.

### 8.3 Hygiene measures when being re-used

Prior to the wheelchair being re-used, it must be carefully prepared. All surfaces which come into contact with the user must be treated with a disinfection spray.

To do this, you must use a suitable disinfectant for rapid alcohol-based disinfection of medical products and medical devices.

Please take into account the manufacturer's instructions for the disinfectant you are using.

#### CAUTION!

1. Do not use solvents, bleaches, abrasives, synthetic detergents, wax polishes, or aerosols.
2. Disinfectants may be used in dilution as specified by the manufacturer.
3. Ensure surfaces are rinsed with clean water and dried thoroughly.

### 8.4 General cleaning instructions

#### CAUTION!

1. You should remove stains on your seat as soon as possible.
2. After a long period of use, you should clean the cover of your seat with a standard commercially available dry foam cleaning agent.
3. You should always clean the whole surface and not just individual spots in order to avoid unattractive edges. The longer you wait the more difficult it will be to remove them.
4. Avoid powerful rubbing with aqueous solutions. This will roughen up cover fabric.
5. Dirt stains (eg. beer, blood, cola, red wine, etc.) are best removed with the dry foam cleaning agents or with a mild action detergent.
6. Please follow the respective instructions of use when treating the covers.
7. The covers should be allowed to dry for at least 48 hours after cleaning with foam cleaning agents.
8. For grease stains (eg. ballpoint pen, lipstick, chewing gum, etc.) use a proprietary stain remover. Carefully rub the soiled location on the surface only with a clean cloth impregnated with the stain remover.
9. Use only a very small quantity of stain remover.
10. Test a small inconspicuous area first.
11. The upholstery material must not be saturated, since the stain remover might then attack it and destroy it.
12. Do not use a hose or pressure washer to clean your chair.

#### WARNING!

1. Always read the label on any commercial or domestic cleaning substances.
2. Always follow the instructions carefully.

### 8.5 Cleaning accessories

All parts/accessories such as swing away trays should be cleaned with a damp cloth.

All lateral supports, headrest, armrests, side-guards, calf pads, lap belts, and knee pads should be cleaned with a damp cloth.

#### Cleaning controls

Should the control of your wheelchair become soiled or dirty, it can be wiped with a damp cloth with a dilute disinfectant until clean.

#### DANGER!

1. This is important should the wheelchair be used by more than one person to ensure there is no cross infection.
2. Ensure that wafer boards, joysticks (all variants), head arrays and switches (all variants) are cleaned with a mild disinfectant and a cleaning cloth to avoid any cross infection possibilities. Following removal from chair, regularly wash the sip and puff mouth piece and tube to maintain cleanliness and functionality.
3. Ensure control is switched off before cleaning.

### 8.6 Medium to long term storage

When storing your wheelchair for long periods of time (in excess of one week), follow these simple instructions.

1. Fully charge the wheelchair for at least 24 hours.
2. Disconnect the charger.
3. Disconnect the batteries.

#### WARNING!

Never store your wheelchair:

1. Outside.
2. In direct sunlight (plastic parts may discolor).
3. Near a source of direct heat.
4. In a damp environment.
5. In a cold environment.
6. With the batteries/battery boxes connected (even if the controller is switched off).

Avoiding all of the above will minimize battery deep cycle discharge and extend battery lifetime. When returning the wheelchair to use, please reconnect the batteries/battery boxes and charge the wheelchair for at least 24 hours before use.

8.7 Maintenance and inspection schedule

To be performed by:

Maintenance and Inspection Schedule	End User / Caregiver			Sunrise Medical Authorized Dealer
	Daily*	Weekly	Quarterly*	Annually
Daily Check routine as described in Section 8.1	<input checked="" type="checkbox"/>			
Weekly Check routine as described in Section 8.1		<input checked="" type="checkbox"/>		
Clean wheelchair upholstery as described in Section 8.2.1		<input checked="" type="checkbox"/>		
Quarterly Check routine as described in Section 8.1			<input checked="" type="checkbox"/>	
<b>Complete inspection, safety check, and service should be made by a Sunrise Medical authorized dealer</b>				<input checked="" type="checkbox"/>

\* Daily = Before each use of the wheelchair. Quarterly = Every three (3) months.

If fasteners are found to be loose a Sunrise Medical authorized dealer should tighten the fastener to the torque setting per size detailed below, unless stated otherwise in all appropriate owner's manuals or instruction sheets (if applicable).

- M8 Fasteners = 13.5-14.9 Nm [120-132 in-lbs]
- M5 Fasteners = 3.1-3.6 Nm [27-32 in-lbs]
- M6 Fasteners = 6.8-7.9 Nm [60-70 in-lbs]
- M4 Fasteners = 0.7-0.9 Nm [6-8 in-lbs]

9.0 TECHNICAL SPECIFICATIONS: APPLICABLE NORMS / STANDARDS



This product complies with the regulations and guidelines for medical aids and carries a CE symbol.

The product meets the requirements and standards below. These are checked by independent institutions.

Standard	Definition / Description	Maximum User Weight
EU guideline 93/42 EEC	Applicable as mentioned in Appendix 1	N/A
NEN-EN 12182:2014 Class B	"The requirements from EN12182 (2014) as mentioned in NEN-EN 12184 (2014): Assistive products for persons with disability - General requirements and test methods"	265 lbs / 120 kg
NEN-EN 12184:2014 Class B	Electrically powered wheelchairs, scooters and their chargers - Requirements and test methods	265 lbs / 120 kg
ISO 7176-8:2014	Requirements and test methods for impact, static and fatigue strengths July 1998	N/A
ISO 7176-9:2009	Climate tests for electric wheelchairs	N/A
ISO 7176-14:2008	Requirements and test methods for control systems for electric wheelchairs 1997	N/A
ISO 7176-16:2012	Requirements for resistance to ignition of upholstered parts May 1997	N/A
ISO 7176-19:2008	Wheelchairs - Part 19: Wheeled mobility devices for use as seats in motor vehicles: The Q-series meet the crash test requirements as described in ISO 7176-19	265 lbs / 120 kg
ISO 7176-4:2008	Wheelchair Energy Consumption Theoretical Range	265 lbs / 120 kg
ANSI/RESNA WC-1:2009	Requirements and test methods for wheelchairs (including scooters) 2009	N/A

## 10.0 SUNRISE LIMITED WARRANTY

### THIS GUARANTEE DOES NOT AFFECT YOUR LEGAL RIGHTS IN ANY WAY.

Sunrise Medical\* provides a guarantee, as set out in the warranty conditions, for wheelchairs to its customers covering the following.

#### Warranty conditions

1. **FOR ONE (1) YEAR** - We warrant all Sunrise-made parts and components of this wheelchair including: motors, gearboxes, and electronic components, against defects in materials and workmanship for one year from the date of first consumer purchase.
2. **BATTERIES** - The batteries are covered by a one (1) year warranty provided through the original battery manufacturers.
3. **LIMITATIONS**
  1. We do not warrant:
    - a. Tires and tubes, upholstery, pads, and push-handle grips.
    - b. Damage from neglect, accident, misuse, or from improper installation or repair.
    - c. Products modified without Sunrise Medical's express written consent.
    - d. Damage from exceeding the weight limit.
  2. This warranty is VOID if the original chair serial number tag is removed or altered.
  3. This warranty applies in the USA and Canada only. Check with your authorized dealer to find out if international warranties apply.
  4. This warranty is not transferable and only applies to the first consumer purchase of this wheelchair through a Sunrise Medical authorized dealer.
4. **WHAT WE WILL DO** - Our sole liability is to repair or replace covered parts. This is the exclusive remedy for consequential damages.
5. **WHAT AUTHORIZED DEALER MUST DO** -
  1. Obtain from Sunrise Medical, while this warranty is in effect, prior approval for return or repair of covered parts. Contact Customer Service for a Returned Material Authorization (RMA) number and information as to where to return the product. Upon contacting Customer Service please provide Model number, Serial number, description of what is required for service/repair, and any additional information as to reason for service being performed to the wheelchair.

#### 6. NOTICE TO CONSUMER -

1. You must pay the cost of labor to repair, remove, or install parts even if they are covered under warranty.
2. If allowed by law, this warranty is in place of any other warranty (written or oral, express or implied, including a warranty of merchantability, or fitness for a particular purpose).
3. This warranty gives you certain legal rights. You may also have other rights that vary from state to state or province to province.
7. This guarantee is subject to the law of the country in which the product was purchased from Sunrise Medical.

\* Denotes the Sunrise Medical facility from which the product was purchased.

### ADDITIONAL WARRANTY INFORMATION FOR AUSTRALIA ONLY

1. For goods provided by Sunrise Medical Pty Ltd in Australia, our goods come with a guarantee by Sunrise Medical that cannot be excluded under the Australian Consumer Law.
2. You are entitled to a replacement or refund for a major failure and for compensation for any other reasonably foreseeable loss or damage.
3. You are also entitled to have the goods repaired or replaced if the goods fail to be of acceptable quality and the failure does not amount to a major failure.
4. The benefits to you given by this warranty are in addition to your other rights and remedies under a law in relation to the goods to which the warranty relates.

Record your serial number here for future reference:

\_\_\_\_\_  
(Refer to Base owner's manual for serial number location)

[www.SunriseMedical.com](http://www.SunriseMedical.com)



Customer Service:  
800.333.4000  
In Canada 800.263.3390

Sunrise Medical  
2842 Business Park Ave.  
Fresno, CA 93727 • USA